



The press fittings series APL, conforming to UNI EN ISO 21003-3, UNI EN 1254-3 and to Ministerial Decree 174, are designed and produced to increase their sealing characteristics and reduce installation times, thus assisting plumbers in system assembly. Provided with double O-Ring seals and with a polyamide lock-ring supporting the pipe sleeve, these fitting are used in sanitary water and heating systems and are available in a range of types and sizes from Ø16 to Ø32.

THE APL SYSTEM

The APL press coupling system has been developed to reach the highest safety level during installation; fittings that are not tight will leak during pressure testing (at up to a test pressure of 6 bar) and can be immediately identified.

The seal between pipe and fitting is guaranteed by the profile of the press fitting and by the presence of two O-Rings [2] positioned in the fitting itself. Using a pressing unit with suitable jaws [see the notes below on pressing profiles] the fitting [4] is permanently deformed and the pressing force in turn deforms the multi-layer pipe onto the specific profile.

The lock-ring [3] has inspection slots that allow to check the correct coupling between pipe and fitting. The thickness of the lock-ring is such as to support high pressures even in the presence of large temperature changes. This ring is in steel type AISI 304 which has been subjected to a further solubilisation treatment for stress relief and to avoid uneven stress developing in time; this heat treatment cancels the stress memory of the material, avoiding any future cracks and leaks.

The presence of the ring [3] insulates the aluminium pipe from the brass pipe, thus avoiding electro-chemical corrosion effects.



HEAD OFFICE
VIA G. GOZZANO 8
25068 SAREZZO(BS)
ITALIA



WAREHOUSE
VIA SALVELLA 20/22
25038 ROVATO(BS)
ITALIA



WEB SITE
ape-raccorderie.com



PHONE +39 030 8920912
ape-raccorderie@pec.it
info@ape-raccorderie.com

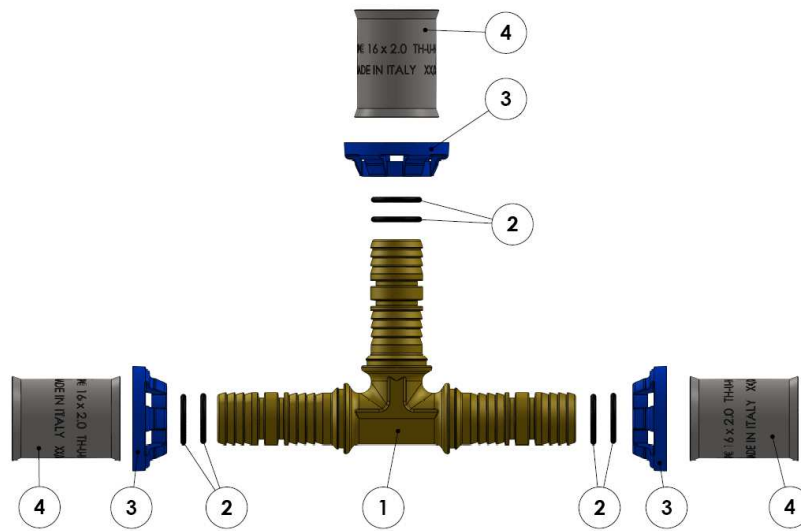

N.	Description	Materials and conformity
1	Body	Brass CW612N CW617N Conforms to UNI EN 12164; UNI EN 12165; UNI EN 12168
2	O-Ring	Peroxide-cured EPDM 70 SCH Conforms to EN 681.1
3	Pipe lock-ring support	B2800 (polyamide)
4	Lock-ring sleeve	Steel AISI 304 Conforms to UNI EN 10088-2

Differing from fittings to be tightened, the coupling in press fittings has the special characteristic of being **immovable**: this means that the APL fitting, when compressed correctly, undergoes a permanent deformation that guarantees long-term sealing. For this reason, press fittings are the only type of coupling that can be used and guaranteed in embedded systems.

Technical characteristics

Field of application:	Sanitary and heating systems
Fluids in use:	Drinking water, technical water (heating etc.), glycol-water mixtures
Glycol percentage:	max 30%
Temperature range:	From -25°C to 120 °C
Working pressure:	max 16 bar
Pipe types:	Multi-layer PE-Xb/AL/PE-Xb (conforming to UNI 21003)

PRESS PROFILES

The APL series fittings can be installed using various press profiles (TH, H, U): to obtain a perfect connection between fitting and pipe and guarantee the best conditions of system performance, it is of fundamental importance to use pressure tools with suitable press profiles and with dedicated dies.

The following table shows the press profile to be used as a function of the diameter:

Diameter			
Ø16 (2.0)	TH	H	U
Ø18 (2.0)	TH	H	U
Ø20 (2.0)	TH	H	U
Ø25 (2.0)	TH	H	
Ø26 (3.0)	TH	H	
Ø32 (3.0)	TH	H	
Ø40 (3.5)	TH		
Ø50 (4.0)	TH		
Ø63 (4.5)	TH		

The illustrations below show the correct position for the crimping tool in relation to the profile: crimping must take place at the correct position with respect to the O-rings, in order to ensure the fitting's tightness.

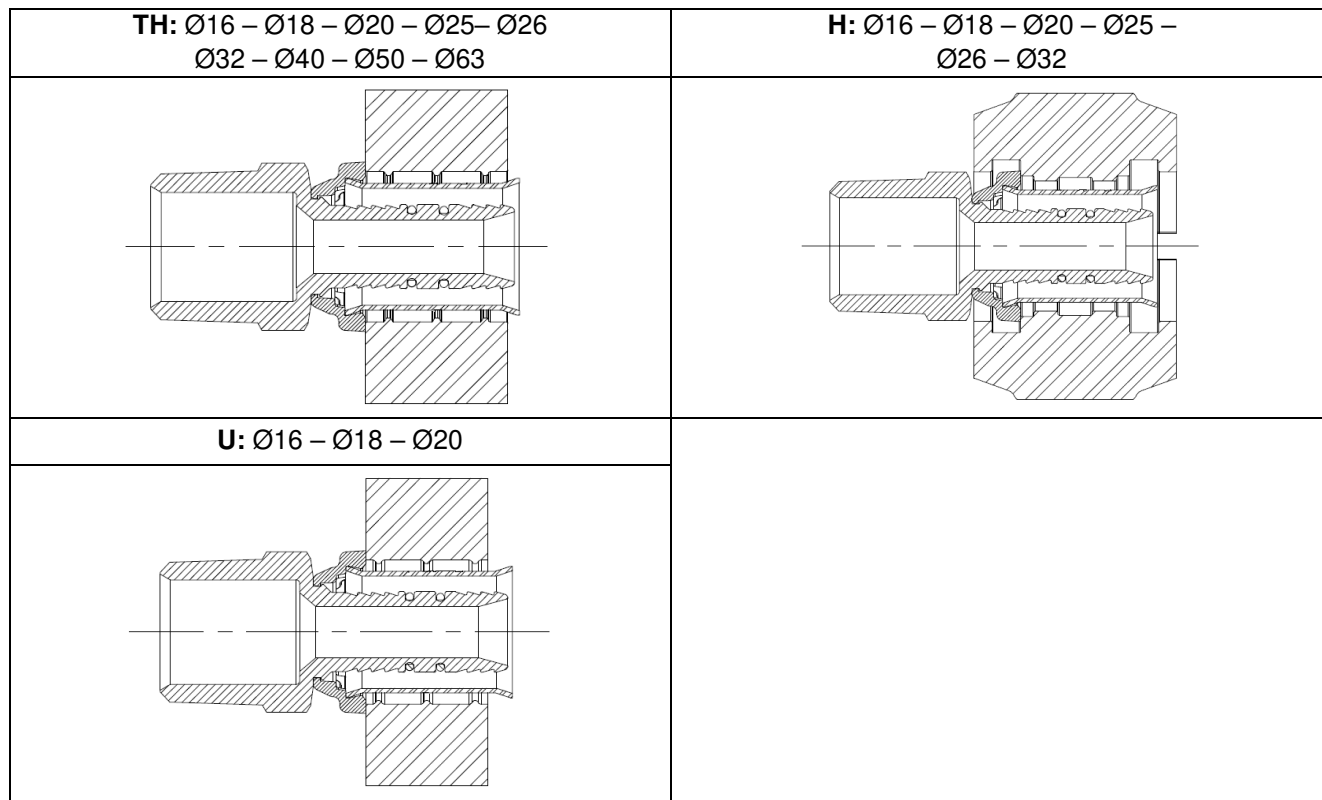

HEAD OFFICE
VIA G. GOZZANO 8
25068 SAREZZO(BS)
ITALIA



WAREHOUSE
VIA SALVELLA 20/22
25038 ROVATO(BS)
ITALIA



WEB SITE
ape-raccorderie.com



PHONE +39 030 8920912
ape-raccorderie@pec.it
info@ape-raccorderie.com

The system composed by **APL fittings** and **APE Multilayer pipe** has been certified by :

- **DVGW** Certificate - DW-8501CR0411
- **KIWA** certificate N° K94485
- **WRAS** Certificate - 1906357
- **ATG** Certificate - 3212
- **AFNOR** Certificate - Admission No 101160, Holder 045
- **AENOR** Certificate - 001/007418
- UNI EN ISO 21003
- DIN 4726
- Ministerial Decree No. 174/2004

APL_EN_0524



HEAD OFFICE
VIA G. GOZZANO 8
25068 SAREZZO(BS)
ITALIA



WAREHOUSE
VIA SALVELLA 20/22
25038 ROVATO(BS)
ITALIA



WEB SITE
ape-raccorderie.com



PHONE +39 030 8920912
ape-raccorderie@pec.it
info@ape-raccorderie.com